

ASME BPE 90° Böj

ASME BPE är en standard för Farmaceutisk, bioteknisk och andra industrier med hygienkrav.

DB0930
101110

Rör i ASME BPE standard, i Syrafast AISI 316L stål.

Materialcertifikat enligt EN 10204-3.1B

Ytfinhet enligt tabell nedan

90° Böj svetsändar, DT-7

Rör YD Tum	A Tum			Artikelnummer - *
1/2	3"			60250-*
3/4	3"			60251-*
1"	3"			60252-*
1 1/2"	3 3/4"			60253-*
2"	4 3/4"			60254-*
2 1/2"	5 1/2"			60255-*
3"	6 1/4"			60256-*
4"	8"			60257-*
6"	11 1/2"			60258-*

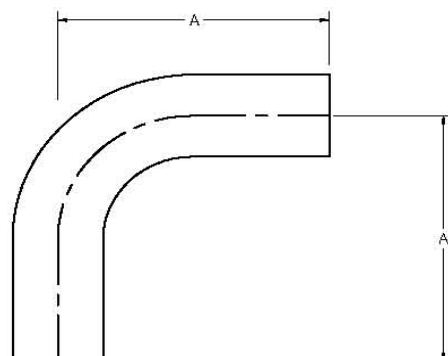

90° Böj med 1xTC, DT-12

Rör YD Tum	A Tum	B Tum		Artikelnummer - *
1/2	3"	1 5/8"		60265-*
3/4	3"	1 5/8"		60266-*
1"	3"	2"		60267-*
1 1/2"	3 3/4"	2 3/4"		60268-*
2"	4 3/4"	3 1/2"		60269-*
2 1/2"	5 1/2"	4 1/4"		60270-*
3"	6 1/4"	5"		60271-*
4"	8"	6 5/8"		60272-*
6"	11 1/2"	10 1/2"		60273-*

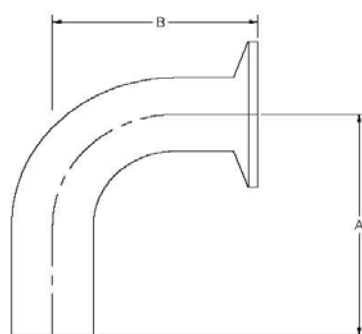

90° Böj med 2xTC, DT-16

Rör YD Tum	A Tum			Artikelnummer - *
1/2	1 5/8"			60280-*
3/4	1 5/8"			60281-*
1"	2"			60282-*
1 1/2"	2 3/4"			60283-*
2"	3 1/2"			60284-*
2 1/2"	4 1/4"			60285-*
3"	5"			60286-*
4"	6 5/8"			60287-*
6"	10 1/2"			60288-*

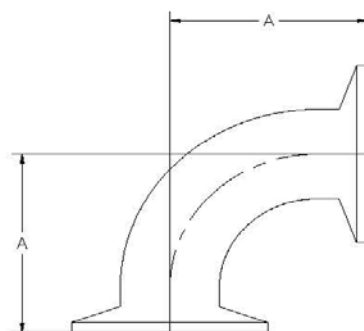

Ytfinish	ID		YD		Tillägg *
	µm	Polering	µm	Polering	
SF1	0,51	Mekanisk	opolerad	-	-3
SF1	0,51	Mekanisk	0,81	Mekanisk	-7
SF4	0,38	Elektropol.	opolerad	-	-3EP
SF4	0,38	Elektropol.	0,81	Mekanisk	-7EP

Andra ytfinheter kan ordnas mot kundspecifikationer.

